



# Cat<sup>®</sup> CS64B

## SMOOTH DRUM VIBRATORY SOIL COMPACTOR

### FEATURES:

The Cat<sup>®</sup> CS64B features a smooth drum and is ideally suited for granular soil applications or cohesive soil applications with the use of an optional padfoot shell kit:

- **Comfortable and ergonomic operator station** features pivoting seat with integrated LED warning panel and control console, outstanding visibility to the front and rear of machine, low sound levels and vibration for greater operator comfort and productivity.
- **Exceptional propel system** built around the exclusive Cat dual pump propel system, two pumps provide separate dedicated flow to drum drive motor and rear axle motor for exceptional gradeability and traction in forward and reverse.

- **Virtually maintenance free** due to maintenance-free hitch bearings and extended maintenance intervals for vibratory system and hydraulic system, providing more uptime and lower maintenance costs.
- **Enhanced compaction performance** due to more weight at the drum and greater amplitude. Auto-vibe function makes it easy to ensure consistent, high quality compaction.
- **Optional Cat Compaction Control** helps the operator determine when compaction has been completed to specification for greater productivity and uniform compaction quality. CMV or exclusive Machine Drive Power (MDP) measurement technology available.

## Specifications

### Engine - Power Train

Engine Model	Cat C4.4 with ACERT <sup>™</sup>	
Global Emissions	US EPA Tier 3/EU Stage IIIA	
Gross Power ISO 14396	96.5 kW	129.4 hp
Displacement	4.4 L	268.5 in <sup>3</sup>
Stroke	127 mm	5 in
Bore	105 mm	4.1 in
Max. Travel Speed (Forward or Reverse)	11.2 km/h	7 mph

### Weights

Operating Weight w/ steel sun canopy	12 055 kg	26,569 lb
Operating Weight w/ ROPS/FOPS cab	12 055 kg	26,569 lb
Weight at Drum w/ steel sun canopy	7120 kg	15,690 lb
Weight at Drum w/ ROPS/FOPS cab	7120 kg	15,690 lb

### Additional Weight with:

Oval Padfoot Shell Kit	+ 1730 kg	+ 3,814 lb
Square Padfoot Shell Kit	+ 1880 kg	+ 4,145 lb

### Vibratory System Specifications

Frequency		
Standard	30.5 Hz	1830 vpm
During Eco-mode Operation	27.7 Hz	1664 vpm
Optional Variable Frequency	23.3-30.5 Hz	1400-1830 vpm
Nominal Amplitude @ 30.5 Hz (1830 vpm)		
High	1.9 mm	0.075 in
Low	0.95 mm	0.037 in
Centrifugal Force @ 30.5 Hz (1830 vpm)		
Maximum	234 kN	52,600 lb
Minimum	133 kN	29,900 lb
Static Linear Load		
w/ steel sun canopy	33.4 kg/cm	186.8 lbs/in
w/ ROPS/FOPS cab	33.4 kg/cm	186.8 lbs/in

### Service Refill Capacities

Fuel Tank, total capacity	242 L	64 gal
Cooling System	25.4 L	6.7 gal
Engine Oil w/ Filter	8.5 L	2.2 gal
Eccentric Weight Housings	26 L	6.9 gal
Axle and Final Drives	18 L	4.8 gal
Hydraulic Tank (service refill)	50 L	13.2 gal



# CS64B Vibratory Soil Compactor

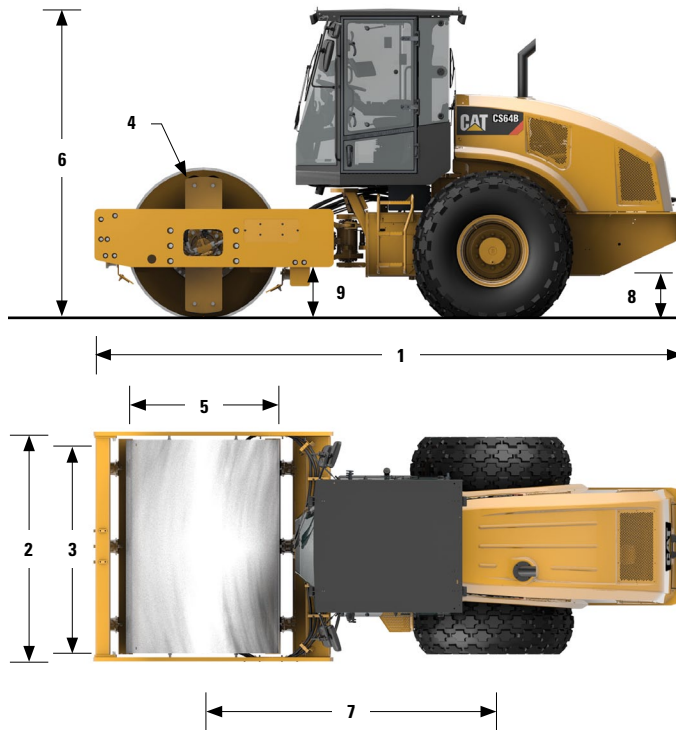

## Dimensions

1 Overall Length	5.85 m	19.21 ft
2 Overall Width	2.30 m	7.53 ft
3 Drum Width	2134 mm	84 in
4 Drum Shell Thickness	25 mm	1 in
5 Drum Diameter	1534 mm	60.4 in
6 Maximum Overall Height	3.11 m	10.2 ft
7 Wheelbase	2.9 m	9.5 ft
8 Ground Clearance	442 mm	17.4 in
9 Curb Clearance	491 mm	19.3 in
Inside Turning Radius	3.68 m	12.07 ft
Hitch Articulation Angle	34°	
Hitch Oscillation Angle	15°	

## Optional Padfoot Shell Kit Specifications

Number of Pads	120	
Pad Height, oval pads	90 mm	3.5 in
Pad Face Area, oval pads	63.5 cm <sup>2</sup>	9.8 in <sup>2</sup>
Pad Height, optional square pads	90 mm	3.5 in
Pad Face Area, optional square pads	123 cm <sup>2</sup>	19.1 in <sup>2</sup>
Number of Chevrons	16	

## STANDARD EQUIPMENT *Varies by market- contact your dealer for specifics.*

### ELECTRICAL

- 24 volt Electrical System
- 75 ampere Alternator
- 750 Cold-cranking Amps Battery Capacity

### OPERATOR ENVIRONMENT

- Open Platform with Handrails/Guardrails, Floor Mat, Steel Sun Canopy
- Vinyl Adjustable Pivoting Seat with Integrated Console and LED Display
- Adjustable Tilting Steering Column with Integrated Cup Holders
- Seat Belt
- 12-volt Power Outlet
- Interior Rear View Mirror
- Horn, Backup Alarm

### POWER TRAIN

- Cat C4.4 Diesel Engine
- Air Cleaner, Dual Element
- Eco-mode
- Dual Propel Pumps; One for Drum Drive, One for Rear Axle
- Fuel Filter, Water Separator, Priming Pump, Water Indicator
- Tilting Radiator/Hydraulic Oil Cooler
- Dual Braking System
- Two-speed Hydrostatic Transmission

### VIBRATORY SYSTEM

- Smooth Drum
- Dual Amplitude, Single Frequency
- Dual Pod-Style Eccentric Weight Housings
- Auto-vibe Function
- Front Adjustable Steel Scraper

### OTHER

- Hydraulic Oil Level Sight Gauge
- Radiator Coolant Level Sight Gauge
- S-O-S<sup>SM</sup> Sampling Valves: Engine Oil, Hydraulic Oil and Coolant

## OPTIONAL EQUIPMENT

- ROPS/FOPS Cab with Heater
- ROPS/FOPS Cab with Climate Control
- Padfoot Shell Kit (oval or square pads available)
- Variable Vibration Frequency
- Beacon, Rotating
- Polyurethane Drum Scrapers
- Steel Rear-side Drum Scraper
- Sun Visor
- Deluxe High-back Air-ride Pivoting Seat (with Cab only)
- LCD Display Unit (Required for Cat Compaction Control option)
- Cat Compaction Control, Machine Drive Power or CMV
- SBAS GNSS Mapping for Cat Compaction Control (RTK available)
- Upgraded Halogen Light Package
- Cab Internal Rear View Mirrors
- Cab Internal Roll-down Sun Screen
- Product Link™
- Additional Rear View Mirrors
- Containerized Shipping
- Fuel Fill Access Door
- Transmission Guard

For more complete information on Cat products, dealer services, and industry solutions, visit us on the web at [www.cat.com](http://www.cat.com)

QEHQ1834 (08-14)

© 2014 Caterpillar  
All Rights Reserved  
Printed in U.S.A.

LRC

Weights and dimensions listed are approximate. Materials and specifications are subject to change without notice. Featured machines in photos may include additional equipment. See your Cat dealer for available options.

CAT, CATERPILLAR, BUILT FOR IT, their respective logos, "Caterpillar Yellow" and the "Power Edge" trade dress, as well as corporate and product identity used herein, are trademarks of Caterpillar and may not be used without permission.

